

LawnMaster®

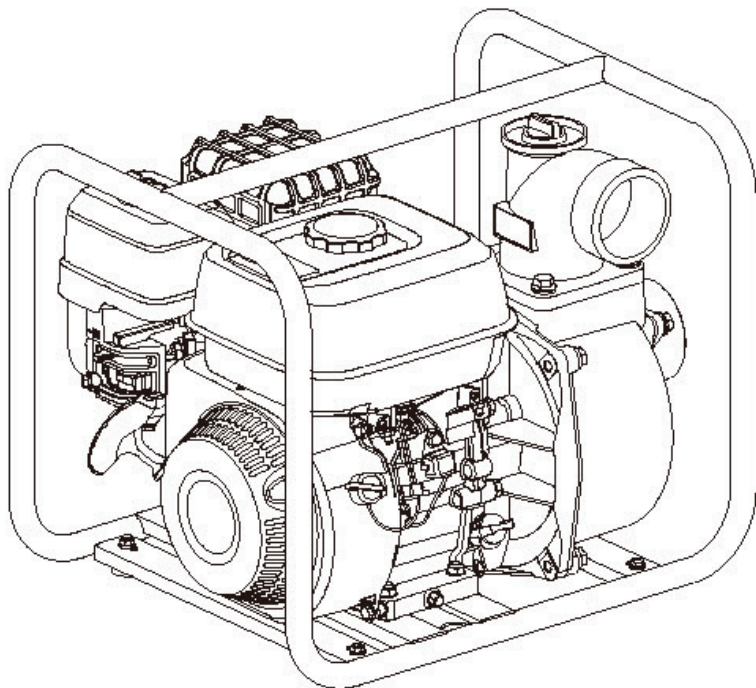

WATER TRANSFER PUMP

SAFETY AND OPERATING MANUAL

PLEASE READ THIS MANUAL CAREFULLY BEFORE OPERATING THE UNIT

LMWPWG20



A STEELFORT PRODUCT



PROUDLY
NZ OWNED



TABLE OF CONTENTS

OPERATOR SAFETY	3
Safety Rules	
FEATURES & TECHNICAL DATA	5
OPERATION & ASSEMBLY	7
Water Pump Connecting	
Connecting the Stainer	
Suction Hose Installation	
Discharge Hose Installation	
Pump Water	
Operating Condition	
Engine Oil/Fuel	
Starting & Stopping Pump	
MAINTENANCE	10
Maintenance Schedule	
Engine Oil	
Changing Oil	
Double Filter	
Foam & Paper Filter	
Spark Plug	
Spark Arrester	
Adjustment	
TROUBLE ANALYSIS & TROUBLESHOOTING	14
STORAGE & TRANSPORTATION	15
WARRANTY	15

Thank you for purchasing our LawnMaster LMWPWG20 Water Transfer Pump, the information contained within this manual will help you to have many years of safe and trouble free use of this LawnMaster product.

OPERATOR SAFETY

SAFETY RULES

This manual contains important safety information and instructions to operate the LawnMaster LMWPWG20 Water Transfer Pump.

PLEASE READ THIS MANUAL CAREFULLY BEFORE USING THE UNIT.

Failure to adhere to the safety instructions could result in property damage and/or serious personal injury.

This manual should be considered a permanent part of the pump and should remain with the unit at all times. All information in this publication is based on the latest product information available at the time of printing.

Product Information and specifications can be altered and/or improved without notice. Content from this publication may not be reproduced without written consent.

DANGER

Indicates a hazardous situation which, if not strictly complied with, will result in substantial property damage and or serious injury.

WARNING

Indicates a hazardous situation which, if not strictly complied with, may result in property damage

CAUTION

Indicates a hazardous situation which, if not strictly complied with, could result in property damage or personal injury.

The warnings and precautions discussed in this manual does not cover all possible conditions and or scenarios that may occur.

It must be understood by the operator that common sense and caution must be taken into consideration

when operating this product, as these are factors which cannot be built into this manual.

DO NOT operate this water pump until you have read ALL safety, operation, and maintenance Instructions listed in this manual. Failure to follow the instructions may result in property damage, INJURY or DEATH.

The warnings and precautions discussed in this manual cannot cover all possible conditions and situations that may occur. It must be understood by the operator that common sense and caution are factors which cannot be built into this product, but must be possessed by the operator.

DANGER

FIRE OR EXPLOSION

- Gasoline is highly flammable and extremely explosive.
- Fire or explosion can cause severe burns or death.
- Keep flammable items away while handling gasoline.
- Fill fuel tank outdoors and in a well-ventilated area with the pump stopped.
- Always wipe off spilled fuel and wait until the fuel has dried before starting the pump.
- DO NOT operate the engine with known leaks in the fuel system.
- Use proper fuel storage and handling procedures. DO NOT store fuel or other flammable materials nearby.
- Empty the fuel tank before storing or transporting this engine.
- Keep fire extinguisher handy and be prepared if a fire starts.

TOXIC FUMES

The exhaust of the pump engine contains carbon monoxide, an odorless, colorless, poison gas. Using engine indoors CAN KILL YOU.

NEVER use inside any building or any kind of enclosure, EVEN IF doors and windows are open.

Place the pump in a well-ventilated area and carefully consider wind and air currents when positioning the pump.

MOVING PARTS

- Moving parts can cause severe injury. Keep hands and feet away.

- DO NOT operate pump with covers, shrouds, or guards removed.
- DO NOT wear loose-fitting clothing, dangling drawstrings or items that could become caught. Tie up long hair and remove jewelry.
- NEVER place fingers, hands, or body near the engine when it is running.
- Fix the pump in case moving or being caught in mud or water, especially when it settles down to the pound or ditches nearby.
- Never drive to run over the transportation pipe. If the pipe must across the road, use plate to hole the pipe over sides to protect from block or press drove by the car.
- Keep the connecting sealing and use explosion-proof pipe for output. Never block the input and output pipe, or it will damage the pump.

WARNING

HOT SURFACE

- Running pump produce heat. Severe burns can occur on contact.
- DO NOT touch pump while operating or just after stopping. Avoid contact with hot exhaust gases.
- Maintain at least three feet of clearance on all sides to ensure adequate cooling.
- Combustible material can catch fire on contact. Maintain at least five feet of clearance from combustible materials.
- Never start the pump without impurities filter in the input pipe.
- Keep enough water in the pump before operate it, do not run it without water in it.
- Make sure users are acquired the knowledge of how to stop the pump quickly and operate all the related devices. No body without enough general understanding of how to operate the pump is allowed to run it. Do not operate the pump if you are under the influence of alcohol, drugs or medication

FIRE

Operation of this pump engine may create sparks that can start fires around dry vegetation. This pump engine may not be equipped with a spark arresting muffler. If the engine will be used around flammable materials, or on land covered with materials such as agricultural crops, forest, brush, grass, or other similar items, then an approved spark arrester must be installed. In some area, a spark arrester is required by law. Please contact local fire agencies for laws or regulations relating to fire prevention requirements.

KICKBACK

Rapid retraction of the starter cord will pull hand and arm towards the engine faster than you can let go. Unintentional startup can result in accident.

WARNING

- Do not use the pump for inflammable or corrosion liquids, chemical solvent, or alkali liquids transport, such as gasoline, alcohol, seawater, oil wine or milk production. Keep the rubber or plastic material far away from oil kinds of stuff.
- Keep hands and body far away from discharge of the pump. Fix the transport pipe the pump so that it can stable during operation. Never put hand or body into the operation pump or transport pipe.
-

This manual applies to the series of the pumps which designed for transfer water with a temperature under 40 °C.

Always place the pump at a level ground to avoid fuel leak.

Operate pump at a ventilative place and keep 1 m away from the wall or other equipment.

Do not use the pump underground or in potentially explosive atmosphere.

FEATURES & TECHNICAL DATA

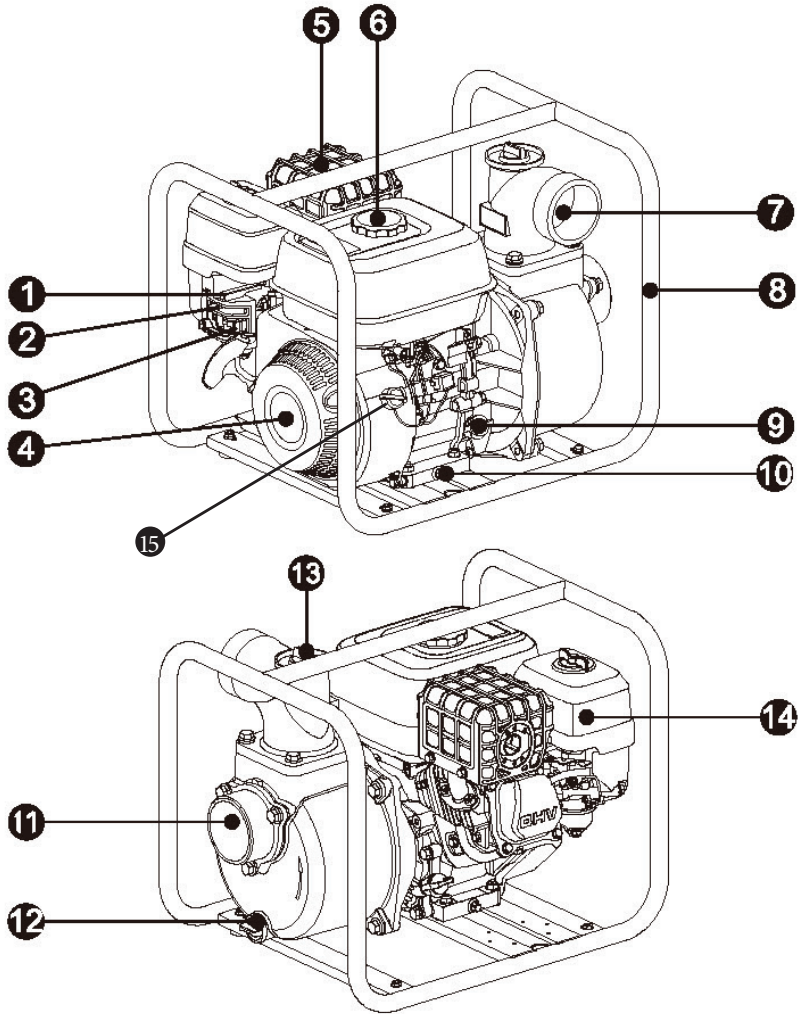

- 1. Throttle Control
- 2. Choke Lever
- 3. Fuel Switch
- 4. Recoil Starter
- 5. Muffler

- 6. Fuel Cap
- 7. Outlet
- 8. Frame
- 9. Oil Dipstick
- 10. Oil Drain

- 11. Inlet
- 12. Outlet Drain Plug
- 13. Inlet Water Plug
- 14. Air Filter
- 15. Remote On/Off Switch

Model	LMWPWG20
Engine Model	GB225
Rated Power (kW)	4.0
Oil Type	SAE 10W-30
Fuel Capacity (L)	4.2
Oil Capacity (L)	0.6
Net Gross Weight (kg)	24
Inlet Diameter (mm)	50
Outlet Diameter (mm)	50
Max. Flow (m ³ /h)	25/35
Max. Head (m)	16/30
Measured Sound Pressure Level dB (A)	92
Measurement Uncertainty dB (A)	1.5
Guaranteed Sound Power Level dB (A)	108
Rated Suction Head	5
Self-Priming Time at 5m (s)	130
Max Speed (r/min)	3800

Note: Any engine and related data of pump changes may not be informed. Engine may difference in various areas, please contact your local dealer for engine information.

OPERATION & ASSEMBLY

WATER PUMP CONNECTING

Check all the following parts after unpacking. Then connect them as follows.

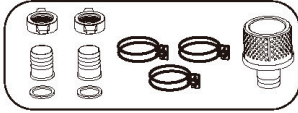

CONNECTING THE STRAINER

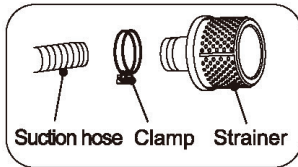

CAUTION

Remember to connect the impurities filter at the end of the input pipe, so that it can prevent from the impurities that may block the pipe or damage any parts.

Keep the inlet pipe filter covered with water so air cannot be sucked into the inlet pipe while the pump is running, also keep the inlet filter off the surface bottom so the filter does not become clogged with mud and reducing the water flow into the pump.

SUCTION HOSE INSTALLATION

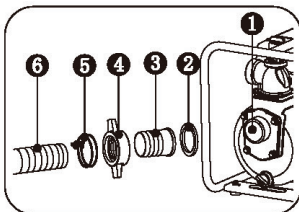

1. Suction Point
2. Hose Coupling Packing
3. Hose Coupler
4. Hose Clamp Ring
5. Hose Clamp
6. Suction Hose

DISCHARGE HOSE INSTALLATION

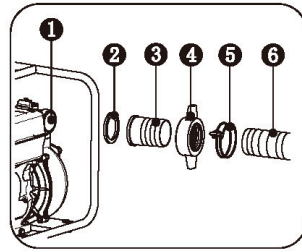

1. Suction Point
2. Hose Coupling Packing
3. Hose Coupler
4. Hose Clamp Ring
5. Hose Clamp
6. Suction Hose

PUMP WATER

Fill the pump before starting it.

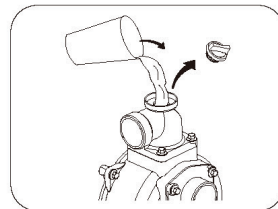

CAUTION

Suction hose must be the unfolded hard pipe but not too long, length should be the direct proportion with the input time. Water hose selection is based on the run condition and purchase model, the discharge hose pressure capacity must meet the requirements for safe. Fasten the clamp so that it cannot loosen under the high pressure on suction or discharge. Large diameter and short length hose is recommended for discharge hose. If keep discharge hose too long or too small diameter, it will increase the flow resistance, which may decrease the pump output.

OPERATING CHECKLIST

For outdoor use only and always keep clean around the water pump. Place the pump in a well-vented area and carefully note the wind and air currents. Place the water pump in a hard horizontal surface before running it, and the pump setting location and its water lift should not over the limited, or it will damage the sealing caused by overheated.

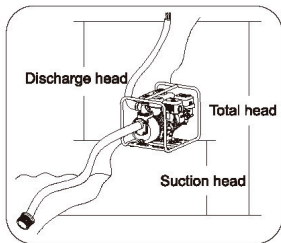

DANGER - TOXIC FUMES

The exhaust of the pump engine contains carbon monoxide, an odorless, colorless, poison gas. Using pump indoors **CAN KILL YOU!** NEVER use inside any building or any kind of enclosure, **EVEN IF** doors and windows are open.

HIGH ALTITUDE

This pump engine may require a high altitude carburetor kit to ensure correct operation at high altitudes. Consult your local dealer for high altitude kit information if you always operate your engine at altitudes above 1,500 meters.

CAUTION

Even with carburetor modification, pump horsepower will decrease about 3.5% for each 300 meters increase in altitude. The effect of altitude on horsepower will be greater than this if no carburetor modification is made.

Operating the pump at altitudes below 1,500 meters with a modified carburetor may cause the pump to overheat and result in serious pump damage.

OPERATING CONDITION

Check for loose or damaged parts, signs of oil or fuel leaks, and any other condition that may affect proper operation. Repair or replace all damaged or defective parts immediately.

WARNING

Failing to correct problem(s) before operation could result in property damage, serious injury or DEATH.

Remove any excessive dirt or debris, especially around the muffler and recoil starter.

ENGINE OIL

1. Place the engine on a level surface with engine stopped.
2. Remove the dipstick and wipe it clean.
3. Insert the dipstick in the dipstick hole, but do not screw it in.

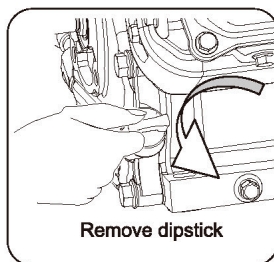

4. Remove the dipstick again and check oil level, which should be in between the upper and lower limit.

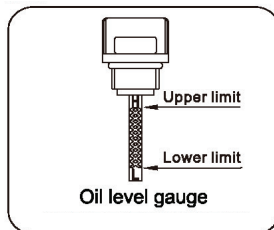

5. Fill to the upper limit (marked with "H") of the dipstick with the recommended oil if the oil level is low.

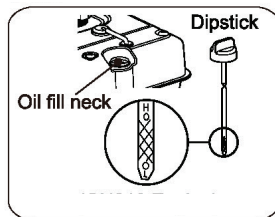

6. Reinstall and fully tighten the dipstick.

Refer to add oil instruction in MAINTENANCE section for more information.

WARNING

Oil is a major factor affecting performance and service life. Use 4 stroke SAE 10w-30 oil which is recommended in the Maintenance section of this manual.

Run unit only in the horizontal surface. If the engine equipped with oil sensor, it will shut off when oil level lower the limit. To avoid unexpected stopping, please fill oil to upper limit and check the oil level regularly.

This pump engine is not filled with oil at the factory. Any attempt to crank or start the engine before it has been properly filled with the recommended type and amount of oil may result in engine damage and void your warranty.

ENGINE FUEL

With the engine stopped, check the fuel level gauge. Refill the fuel tank if necessary.

CAUTION

Pressure can build up in the fuel tank. Allow the engine to cool for at least two minutes before removing fuel cap. Loosen the fuel cap slowly to relieve any pressure in the tank

- Use clean, fresh, regular unleaded gasoline with a minimum octane rating of 91.
- DO NOT mix oil with gasoline.
- Be sure not to fill above the upper limit mark, always fill to regulated level like level indicator shows, or fill to 25mm left from fuel tank, lower the fuel level according to engine start condition and allow room for fuel expansion.

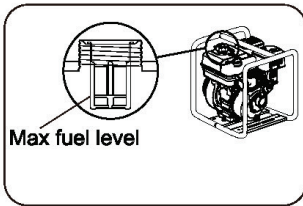

DANGER

Do not fill the fuel tank above the upper limit. Over fill will result in engine die or damage the carbon canister (if equipped) and void your warranty.

DANGER - FIRE OR EXPLOSION

- Gasoline is highly flammable and can be explosive.
- Keep flammable items away during handling.
- Use gasoline outdoors in a well-ventilated area.
- Wipe off spills and ensure fuel is dry before starting equipment.
- Never operate machinery with fuel leaks.
- Store fuel safely, away from heat sources.
- Empty fuel tanks before storage or transport.

- Keep a fire extinguisher nearby for emergencies

Avoid using engine or carburetor cleaner in the fuel tank to prevent damage.

Prevent gum deposits in fuel system parts during storage. Alcohol-blended fuels can attract moisture, causing damage; follow storage instructions.

Only use gasoline/alcohol blends with up to 10% alcohol; other blends are not approved. Old, stale, or contaminated fuel is not covered by warranty.

CAUTION

To minimise gum deposits in your fuel system and to insure easy starting. Always use fresh fuel when operating the pump.

START THE PUMP

1. Check the item before operating the pump.
2. Turn engine switch to "ON" or "-" position.

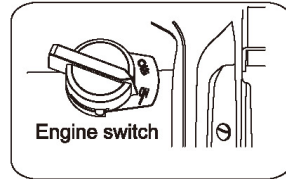

3. Slide the choke lever to the left and the fuel lever to the right to allow fuel to flow to the engine

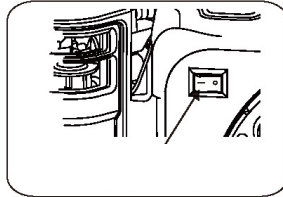

4. Turn the throttle lever 1/3 from low speed to high speed.

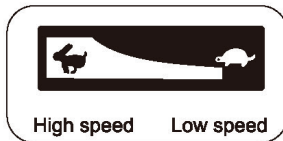

CAUTION

Whether choke open or not may be varied with temperature or other factors, for instance, if heat engine re-started above 20c , the choke should be open, while re-started below 20c, the choke should be closed.

RECOIL START

WARNING

Check recoil rope before start. If rope got abrasion severely, please exchange in your local dealer.

1. Pull the starter handle until feel resistance force to start the engine, and then pull more quickly to start it.

WARNING - KICKBACK

Rapid retraction of the starter cord will pull hand and arm towards the engine faster than you can let it go. Unintentional startup can result in accident.

2. Switch on the choke lever right after engine started successfully. Do not run engine for long time with choke lever off.
3. Turn the throttle lever to high speed to run the engine under standard speed.

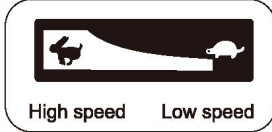

STOP THE PUMP

1. Turn the throttle lever to low speed to run engines more 1-2 minutes.
2. Turn the switch to OFF position or 0 position to stop the pump.

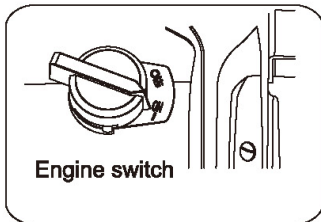

3. Turn off the fuel switch.

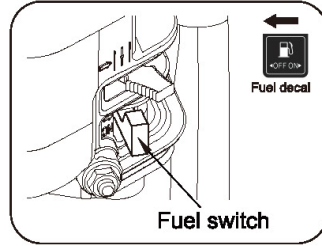

MAINTENANCE

It is owner's/operator's responsibility to complete all scheduled maintenance in a timely manner. Correct any issue before operating the pump.

Always follow the inspection and maintenance recommendations and schedule in this manual.

DANGER

Accidental starts can cause severe injury or death. Remove and ground spark plug wire before performing any service.

WARNING

Improper maintenance or failure to correct a problem before operation can cause a malfunction and result in property damage, serious injury or DEATH. Improper maintenance will void your warranty.

CAUTION

The filter element may contains PAHs, PAHs are harmful for your health. Please wear gloves for protection during air filter maintenance.

MAINTENANCE SCHEDULE

Service the water pump in a clean, dry and dusty area. Follow the service intervals indicated in the chart below. Service your water pump more frequently when operating in adverse conditions. Contact your local LawnMaster service dealer for your water pump maintenance needs.

		EACH TIME BEFORE & AFTER USE	FIRST MONTH OR FIRST 20H	EVERY 50H OR 3 MONTHS	EVERY 100H OR 6 MONTHS	EVERY 300H OR 12 MONTHS
Fasten Parts	Check	✓				
Engine Oil	Oil Level Check	✓				
	Oil Change		✓	✓		
Air Filter	Check	✓				
	Clean *1			✓		
	Change *1					✓
Spark Plug	Check & Adjust				✓	
	Change					✓
Idle Speed	Check & Adjust *2				✓	
Valve Gap	Check & Adjust *2				✓	
Combustion Chamber	Clean *1	Clean Every 200h				
Gasket on Cylinder	Clean *1				✓	
Fuel Tank	Clean *1				✓	
Fuel Pipe System	Clean *1	Clean Every 2 Years (change new one if needed)				
Pump	Clean *1					✓
Cooling Fan	Check					✓
Pump Water Intake Valve	Check					✓

* 1: More frequent maintaining is required when engine run in the multi-dust or severe condition.

* 2: All maintaining should be done by a LawnMaster Service Dealer.

GENERAL MAINTENANCE

ENGINE OIL

SAE 10W-30 is recommended for general, all-temperature use. Other viscosities shown in the chart may be used when the average temperature in your area is within the indicated range.

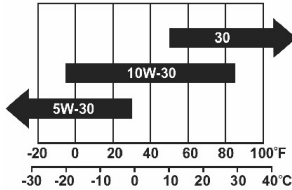

ADD OIL

1. Place the engine on a level surface.
2. Remove the dipstick and wipe it clean.

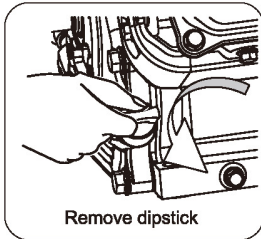

3. Add the oil of the recommended type to the upper limit of the dipstick.

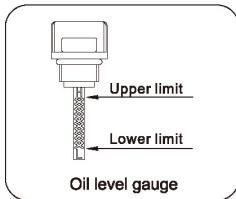

CAUTION - OIL LEVEL CHECK

Re-insert the dipstick to the oil fill hole and keep it in the neck. Do not screw it into the oil fill.

4. Completely screw the dipstick.

CHANGE OIL

CAUTION

Change oil when the engine is warm from operation.

1. Place the engine on a level surface.
2. Clean area around dipstick and drain plug.
3. Remove oil dipstick.
4. Remove the oil drain plug and allow the oil to drain completely.
5. Replace and fully tighten the drain plug.
6. Add recommended oil to the upper limit (see add oil instruction above).
7. Reinstall and fully tighten the dipstick.
8. Dispose of used oil at an approved waste management facility.

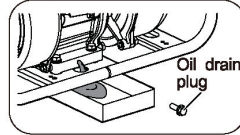

WARNING

This pump engine is not filled with oil at the factory. Any attempt to crank or start the engine before it has been properly filled with the recommended type and amount of oil may result in engine damage and void your warranty.

DOUBLE FILTER

1. Loosen the nut to remove the filter cover.

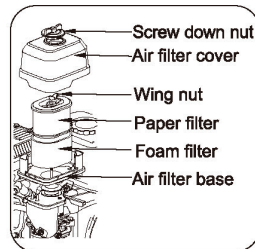

2. Loosen the wing nut to remove the filter.
3. Cleanup the filter.
4. Reassemble the filter back to the units.
5. Fasten cover with the screw down nut.

FOAM FILTER:

Put the foam element into hot water with detergent, to throughout dry the element, wrap and press it in the clean and water sucking fabric. After cleaning soak it in the clean oil for a while before wrap and press it in the clean and water sucking fabric again.

PAPER FILTER:

Tap lightly to soft the hard filter from its inside to outside so that the dirt can fall off. Never brush the dirt, which may make the dirt into paper filter. Change a new paper filter if it is too dirty.

WARNING

DO NOT run the engine without the air filter.

SPARK PLUG

Bosch WR7DC+ / NGK BPR7ES

1. Remove any dirt from the spark plug cap and base.
2. Take off the spark plug cap.
3. Use a socket wrench to loosen and remove the spark plug.
4. Inspect the spark plug and its washer. If damaged or worn, replace them. If reusing, clean the spark plug with a wire brush.
5. Check the spark plug gap. If needed, carefully adjust the gap by bending the side electrode.

Spark plug gap: 0.6mm - 0.8mm

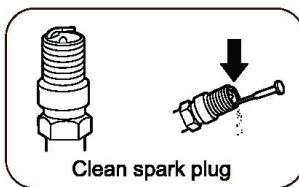
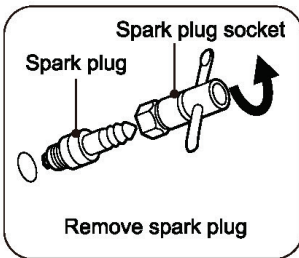

6. Attach the spark plug wire to the plug.
7. Carefully thread the plug into the engine by hand.
8. After the spark plug seated, use spark plug wrench to tighten it.

Spark plug tighten torque: 20-25 N.m

9. Attach the spark plug boot to the plug.

WARNING

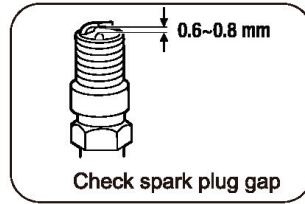

Only use recommended spark plug or equivalent. DO NOT use spark plugs that have improper heat range.

SPARK ARRESTER

(Applicable Types)

1. Allow the engine to cool completely before servicing the spark arrester.
2. Remove the two screws holding the cover plate which retains the end of the spark arrester to the muffler.
3. Remove the spark arrester screen.
4. Carefully remove the carbon deposits from the spark arrester screen with a wire brush.

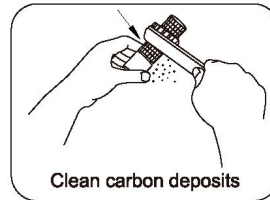

ADJUSTMENT

No additional service or adjustments are required for your engine. Making unauthorised adjustments or tampering can harm your engine and electrical devices, invalidating your warranty. For any necessary service, please contact your local LawnMaster dealer.

WARNING

Tampering with the factory set governor will damage your engine and void your warranty.

TROUBLE ANALYSIS & TROUBLE-SHOOTING

Item	Problem Shooting	Solution
Engine can hardly start or cannot start / low power	Throttle closed	Open the throttle governor
	Stop switch closed	Turn the switch to ON or - position
	Choke opened	Close the choke
	Carbon store in spark plug	Remove the carbon accumulation
	Spark plug and ignition gap large or small	Adjust the gap to standard value
	Spark plug damage	Replace
	Inferior oil or fuel is used.	Change new fuel or oil
	Engine works over loaded or over heated	Check the engine work condition
	Insufficient oil	Add oil to standard level
Pump cannot work or low water flow after engine start	Impurities filter blocked	Check and remove the impurities
	Insufficient water in pump	Unscrew the rubber plug to fill enough water
	Problem on water pipe like block, loosen, leak and pipe length too long or diameter too narrow.	Check the water pipe and adjust
	Input pipe is not in the water	Check and put it into water
	Input pipe leak	Check the connecting
	Pump mounting too high	Lower the mounting height
	Engine works low speed	Turn the throttle governor to high speed

If problems still not be solved according to above problem shooting or other problem caused during operation, contact your local authorised LawnMaster dealer for help.

Unauthorised disassemble on the pump will void your warranty.

STORAGE & TRANSPORTATION

STORAGE

The pump should be started at least once every 2 weeks and allowed to run for at least 20 minutes. Follow the instructions below for a long term storage if the pump will be out of service for 2 more months or more longer.

DANGER - FIRE OR EXPLOSION

Gasoline is highly flammable and extremely explosive. Empty the fuel tank and shut off fuel valve before storing or transporting this pump.

1. Remove oil as maintenance and service chapter indicate when pump engine is hot after running.
2. Allow the pump to cool completely.
3. Drain all fuel completely from the fuel tank, fuel hose and carburetor.
4. Remove spark plug and pour about 1 oz. of engine oil into cylinder. Reinstall spark plug. Crank pump slowly to distribute oil and lubricate cylinder.
5. Pull the recoil till resistance is felt.
6. Remove the water outlet plug, and clean the pump with pure water, and then drain all the water before reattach the plug.
7. Clean the appearance of the pump and shield the pump in case of dusty accumulation.
8. Store the unit in a clean, dry area, and out of direct sunlight.

WARRANTY

Subject to the following conditions, this unit is covered by a comprehensive two-year warranty.

The unit is designed for domestic purposes only, issues and faults due to commercial use may not be covered by warranty. The warranty covers all manufacturing faults but excludes normal wear and tear, misuse, neglect, accidental damage or defects arising from failure to comply with instructions as outlined in this owners manual. Only genuine spare parts can be used for repairs and this must be carried out by an authorised LawnMaster Services Dealer to maintain warranty.

Warranty does not cover the cost of transportation of any part(s) but does cover the labour/parts cost incurred in repairing or replacing any defective part(s) consequential or special damages and / or expenses resulting from any defect.

If the unit requires further repairs or services please visit www.lawnmaster.co.nz to find your local LawnMaster dealer.

For all other enquiries contact **Steeffort Customer Services +64 6 350 1350**

TRANSPORTATION

To prevent fuel spillage when transporting or during temporary storage, the pump should be secured upright in its normal operating position, with the switches OFF.

WARNING - TRANSPORTING

Do not over fill the tank. Avoid a place exposed to direct sunlight when putting the pump on a vehicle. If the pump is left in an enclosed vehicle for many hours, high temperature inside the vehicle could cause fuel to vaporize resulting in a possible explosion. Do not drive on a rough road for an extended period with the engine on board. If you must transport the engine on a rough road, drain the fuel from the engine beforehand.

LawnMaster®

FIND US



www.lawnmaster.co.nz



lawnmasternz

Steelfort

500 Rangitikei Street, Private Bag 11045
Palmerston North, 4412, New Zealand
06 350 1350

Steelfort Auckland

880 Great South Road, Penrose
Auckland, 1061, New Zealand
09 573 1324